

Auramarine fuel supply systems



**A RELIABLE CHOICE
FOR ALL SHIP TYPES**



Auramarine fuel supply systems

Auramarine fuel supply units meet critical fuel circulation needs whether the ship's engines run on Heavy Fuel Oil (HFO), Marine Gas Oil (MGO) Biofuel or Methanol, or a combination of these fuels.

Coping with existing and future bunker regulations, and the variety of fuel blends in daily operations, can be challenging for a ship's crew and its equipment.

Auramarine fuel supply units ensure that a fuel's condition continuously satisfies engine-specific requirements, taking care of fuel filtering, heating and cooling. Auramarine offers fuel supply systems that control the injection viscosities, flow rates and fuel pressures for different fuel types and engine configurations.

All Auramarine fuel supply systems are designed and manufactured to fit seamlessly into a ship's fuel system and provide safe operations for the fuel in use..

Our solutions comprise a standardised configuration and extensively customisable configurations with a wide range of options and functions:

1. **AMB-Mc series 02-07: a compact, standardised solution with a select number of options for up to 10MW**
2. **AMB-M series 12-26: a customisable series for up to 25MW**
3. **AMB-M series 36-60: a customisable series for up to 60MW**
4. **Marine Gas Oil supply units**
5. **Methanol supply systems**
6. **Biofuel supply systems**

Design

- compact designs enable operators to maximise revenue-generating spaces on board a vessel
- horizontal heaters ensure easy access for servicing, while vertical heaters offer compact designs
- the flexible addition of functions, during the tendering phase, can be achieved by increasing the frame size
- other individual Auramarine units can be connected to the unit later on
- front-facing pipe connections are standard and customised rear-facing pipe connection solutions are also possible

Installation

- a proven design supports fast and simple installation
- programmable logic controllers (PLC), using BUS connections, ensures reduced cable work, minimising installation costs and the risk of installation errors

Commissioning

- project-specific values are set during factory testing, which reduces the need for adjustments during commissioning
- commissioning support available

Operation

- user-friendly operation, with all essential operational parameters visible at a glance thanks to separate instrument displays
- proven reliability and safety thanks to shell- and tube-type heaters and separate viscosity and temperature controls
- controlled via PLCs
- frequency converters can control feeder and booster pumps
- accurate fuel-consumption monitoring with BUS communication and onboard data systems enabled
- for safe and controlled fuel changeovers, Auramarine's fuel changeover system, FuelSafe™, can be integrated as a part of the configuration

Service and maintenance

- the best available components, carefully chosen materials and sophisticated manufacturing methods offer a long lifespan and flawless operation
- serviceable components are easily accessed and service space is optimised
- experienced global service and maintenance support throughout the lifecycle of your asset

Main features:

- 1.** A wide range of capacities
- 2.** Multiple optional functions
- 3.** Flexible component arrangements accommodate units in the space available

Methanol supply systems



Example of an arrangement

Built on Auramarine's technical fuel supply system expertise

The methanol fuel supply unit is designed based on the technical capabilities of our advanced fuel supply management systems. On this solid foundation, we have built expert knowledge about methanol fuel system requirements in dialogue with leading engine makers and ship owners.

Auramarine's methanol fuel supply unit is suitable for both two-stroke and four-stroke engines.

Our unit supplies methanol from the service tank to the engines and other methanol consumers. It regulates fuel pressure and actively maintains the supply pressure within the specified tolerances during load changes. It also regulates the fuel temperature and filtrates the fuel to prevent any impurities from entering the fuel consumer.

Benefits for shipyard and installation

- Clear, modular and installation-friendly designs
- Pre-tested units shorten installation and commissioning times
- Classification certificate is delivered for the full fuel supply unit
- The design can be optimised for the exact space available
- Solutions available also for retrofit installations

Contact us for more information:

e-mail sales@auramarine.com
or scan the QR code to send us an inquiry:



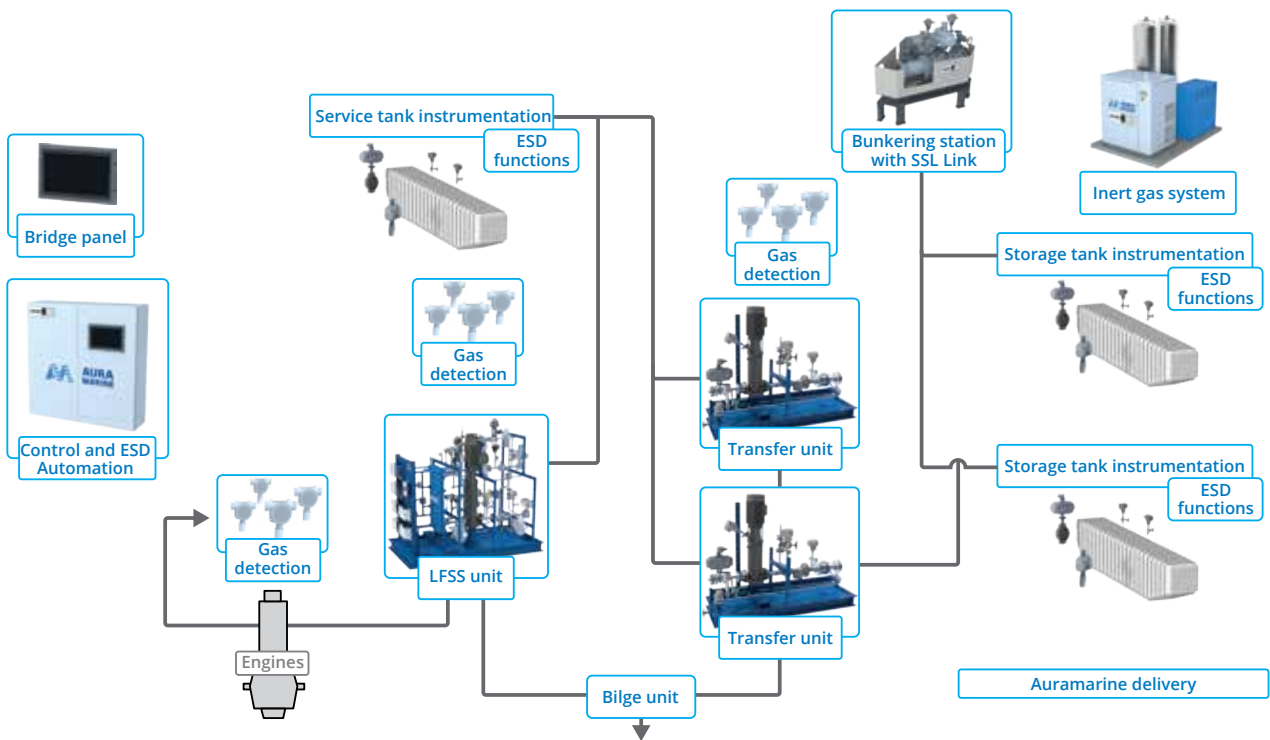

A typical arrangement

Benefits in operation

- Consistent, high-quality design and components ensure reliable and safe operation
- Duplex filter enables filter replacement when unit is in operation
- Fuel consumption metering is available via flow meter
- Spare part services ensures the availability of right parts at right time
- All fuel supply system materials and manufacturing procedures are designed suitable for methanol service and for the specifications of a particular application
- The unit, its components and electrical equipment is designed to be installed in closed and Ex rated hazardous areas. All IECEx and Health and Safety Guidelines (HSE) have been taken into account
- The unit has a self-draining mechanical design, nitrogen inerting, and double block and bleed arrangement for all serviceable methanol line segments
- The electrical cabinets, control panels and variable frequency drives are designed to be placed separately to safe area

Synergies and benefits from choosing the methanol system and its backup from Auramarine

- The purchasing process is straightforward, less administration work from a shipyard perspective at the shipbuilding stage
- The design can be optimised for the exact space available
- All documentation is from one supplier, which brings benefits in operation
- There is one contact point for all the equipment
- If a service is needed, our service engineer can check the status of all Auramarine's equipment at the same time for safe and reliable operation
- Auramarine's Lifecycles Services ensure the operational efficiency of your fuel supply and auxiliary systems throughout their lifetime

Standardised units

AMB-Mc 02-07

To ensure that units meet the required injection viscosities, flow rates and pressures for the various specified fuel types and engine configurations, each unit is offered independently with detailed specifications.

- Can be used to supply fuel to either main or auxiliary engines
- Cost savings through standardised components
- Compact design for fast and trouble-free installation
- Easy maintenance: access is only required at the front and right side of the unit
- Standard option comprises separate feeder and booster components
- Maximum power serviceable: up to 10MW
- Dimensions (including service space): 1.5m x 2.9m
- Frame size is standardised with a few select options



A compact, standardised Auramarine AMB-Mc fuel supply unit with a vertical heater

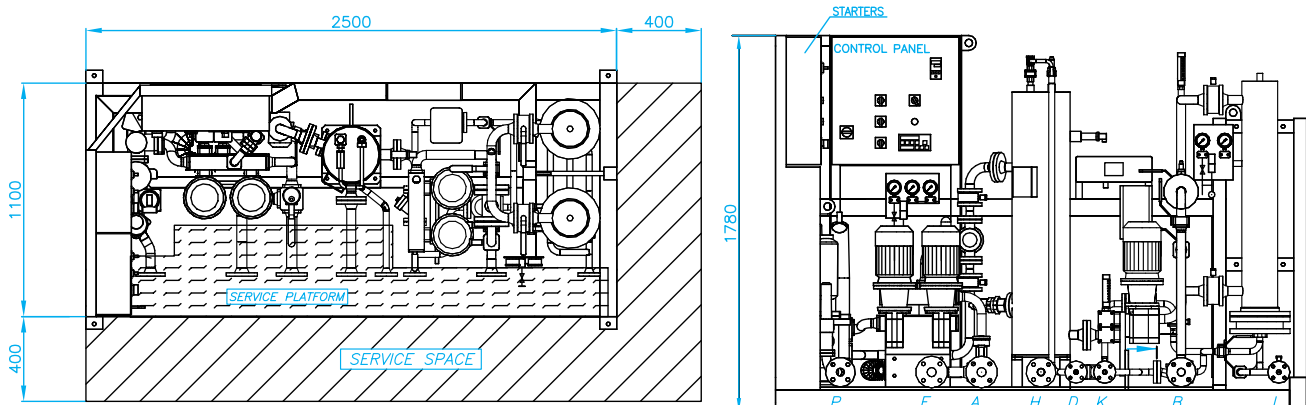

Schematic diagram of a compact, standardised Auramarine AMB-Mc fuel supply unit with a vertical heater

Customer-specific solutions: AMB-M series

The two size ranges of the Auramarine M-series fuel supply units are specified depending on the engine power they will serve. They can be extensively customised to meet all customer-specific requirements. For typical options, please see page 8.

AMB-M 12-26

- Maximum power serviceable: 25MW
- Dimensions (including service space): minimum 3.60m x 2.20m
- This frame size can expand depending on optional additional features

AMB-M 36-60

- Maximum power serviceable: 60MW
- Dimensions (including service space): minimum 5.00m x 2.60m
- This frame size can expand depending on optional additional features
- For installations over 60MW, solutions are available upon request



An Auramarine AMB-M 36-60 series fuel supply unit

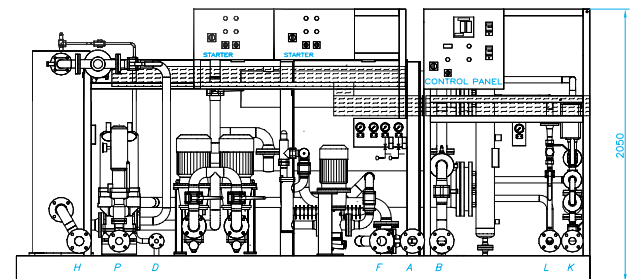
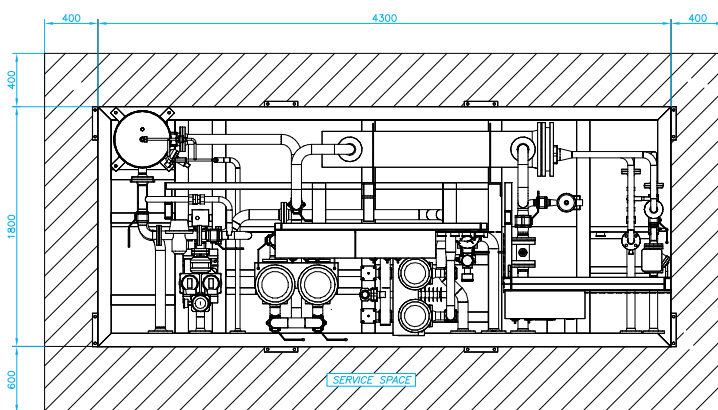

Schematic diagram of an Auramarine AMB-M 36-60 series fuel supply unit

Typical AMB-M components and options

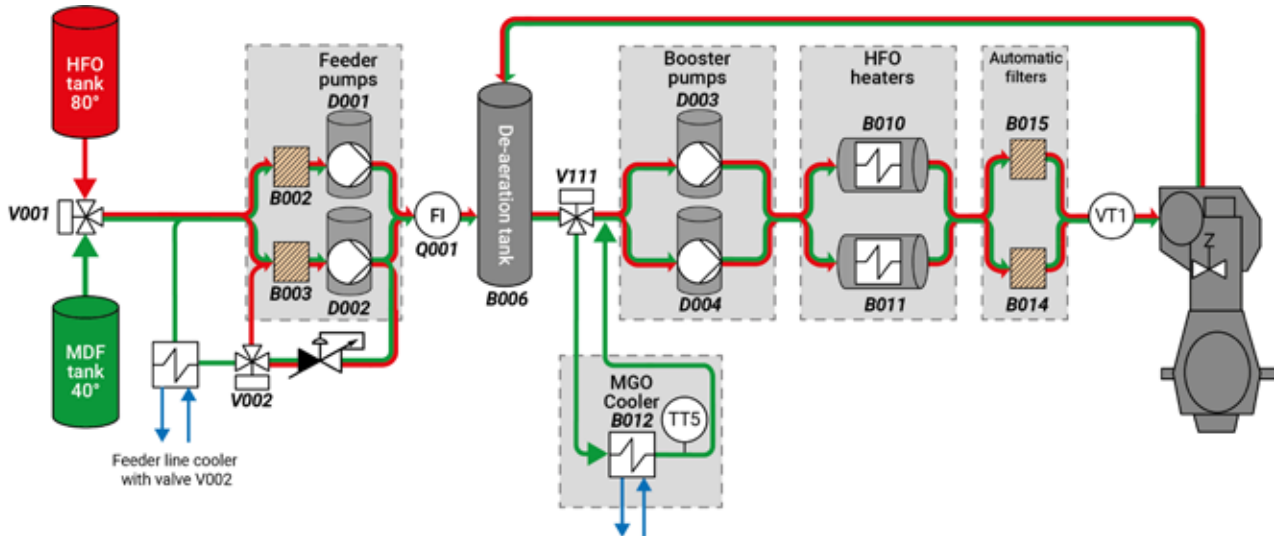

Fuel changeover system for seamlessly switching between different fuel types. The system comprises **V001 3-way valve**, **V002 valve and feeder line cooler**, **V111 valve** in line with the cooler unit, **a cooler** and a **motor valve M**. All valves are available as automated or manual configuration, depending on the specification. For more information about fuel changeover system, see page 11.

HFO/MGO 3-way changeover valve (V001) for selecting fuel and flushing the system. Changeover valves and feeder pumps can be ordered as separate units and can be remotely or manually controlled.

Suction strainers (B002, B003) for protecting the pumps.

Feeder pumps (D001, D002) for pressurising the system with fresh fuel according to the consumption requirements of the engines. They are equipped with an automatic stand-by function and have magnetic or mechanical couplings. If a separate feeder unit is ordered, the booster unit does not include feeder pumps.

Pressure control valve (V010) for maintaining constant system pressure at different loads. This is supplied with or without a bypass system.

Automatic filter with bypass filter (B014, B015) for removing impurities from fuel oil and indicating purification system failures. They are equipped with automatic cleaning and pressure-difference indicators. The degree of filtration is specified according to the engine manufacturer's recommendation or a customer's requirements.

Flowmeter (Q001) for indicating fuel consumption. Flowmeters have a local totalizer and output signal. They are available as mass or volumetric types.

Mixing tank (B006) for mixing the return fuel from the engines with fresh fuel and to help compensate for temperature and pressure changes. De-aeration is achieved manually or automatically.

Booster pumps (D003, D004) for further pressurising and circulating fuel to the engines. They can be equipped with an automatic stand-by function and have magnetic or mechanical couplings. If needed, an individual circulating pump can be delivered for each engine.

Fuel heaters (B010, B011) for heating fuel oil to the correct injection viscosity, is controlled via a viscometer. Steam heating (SS), thermal oil heating (TT) or electric heating (EE) options are available.

Viscosity control system (B016) for measuring the fuel viscosity and controlling the power of the heaters to maintain constant injection viscosity, secured by a temperature controller. secured by a temperature controller.

One or two MGO pumps (D005, D006) for securing a separate MGO supply to auxiliary engines while running the main engines with HFO. If a separate MGO pump unit is ordered, the booster unit does not include MGO pumps.

Auramarine Cooler Unit (ACU) for cooling fuel to the correct injection viscosity. If the cooler is built into the booster unit a separate ACU unit is not required.

If there is not enough sufficiently cool LT-water/seawater available for the ACU-unit, or if the MDF fuel type is such that it needs to be cooled to temperatures below 40°C to meet the minimum viscosity specified by the engine manufacturer, an **Auramarine Modular Chiller (AMC)** can be supplied as an option for additional fuel cooling.

Optional features

- Viscosity signal (mA) can be relayed to the engine control room (ECR)
- Viscosity controller can be delivered separately for installation in the ECR
- Changeover valve position indication and control
- Fuel consumption signal (mA or pulse) can be relayed to the ECR
- MDO/MGO pumps can be controlled according to the type of pump chosen
- Temperature signal (mA or PT-100) can be relayed to the ECR
- Additional displays for the ECR
- Frequency converter-driven pumps
- Programmable logic controllers (PLCs)

Marine Gas Oil supply units



Auramarine Marine Gas Oil supply units are ideally suited for operators using single-fuel marine gas oil (MGO) or dual fuel systems.

Each system is configured to meet a customer's needs and backed-up by proven long-term reliability and operational performance.

Dual fuel systems

The significantly different properties of heavy fuel oil (HFO) and low-sulphur fuels in multi-fuel systems require careful fuel condition management; an expert approach is essential. In most marine diesel engines, the viscosity of the fuel needs to be at least 2.0 cSt. The viscosity of all fuels must be stabilised and controlled through heating (HFO) or cooling (MGO). This is crucial for engine and fuel system health.

MGO systems

Low sulphur fuels, such as MGO, generally have a low viscosity and do not usually fulfil the minimum viscosity requirements of main engines. The viscosity of MGO can be increased to meet these and lubrication requirements by cooling the oil with Auramarine's ACU series of fuel oil coolers.

For operators only using MGO, heaters are not usually required, as a result, Auramarine marine feeder booster units can also be supplied without heaters.

Main features

- Auramarine's solutions for controlled cooling comprise **a cooler unit, a chilling unit when needed, and a cooling water circulation unit**. Together they enable the fuel to be cooled to temperatures below 20°C.
- For operators looking to switch to low-sulphur fuels, Auramarine MGO supply units can be fitted to both new and existing vessels.
- MGO supply units are easy and flexible to install either as independent components, or as part of a compact, integrated unit. In both cases, they optimise the use of available free space.
- Turn-key deliveries are available

A sustainable future with biofuels



Liquid biofuels

Liquid biofuels are among the most feasible and effective low-carbon fuel options available. Many of them can be used as drop-in replacement fuels, meaning they can be used in existing engines with little to no modification.

Meeting regulatory requirements

With stringent environmental regulations on the rise, biofuels offer an alternative fuel that can help shipowners meet these requirements. They provide a way to achieve regulatory compliance without the need for expensive exhaust gas cleaning systems (scrubbers) or extensive engine modifications.

Long-term solutions

Whether a newbuild or retrofit, planning for your energy transition early can give your business a strategic advantage. Auramarine can work in collaboration with your team to discuss various biofuel options and find the best solutions not only for the near future, but to allow flexibility and continued operations throughout the asset's lifetime.

Investing proactively can mean more accurate data gathering and reporting for pressure, bacteria and algae situation, and filtering monitoring, resulting in earlier risk detection. The system can also be equipped with a number of local indicators and transmitters and related alarms. This wealth of data can also support efficiency calculations.

The following features may or may not be needed when biofuel is introduced to the system:

- Acid-proof materials
- Capillary transmitted pressure gauges, switches and transducers
- Surface temperature control through technical solutions
- Enhanced initial heating
- Preheating for backup fuel
- Automatic filters

Water separation from biofuel must be handled carefully in the fuel oil system before oil enters the unit to avoid microbial growth and related corrosion mechanisms.

Your expert in biofuel systems

Given the complexities involved with different biofuel types and their specific requirements, it pays to work with an expert in biofuel systems. Auramarine has been designing biofuel units since the early 2010s, gaining extensive experience and expertise in this field.

Auramarine delivered its first biofuel supply units in the early 2010s and has since been a trusted provider. The Technical Research Centre of Finland has also relied on Auramarine's biofuel equipment for their research projects, underscoring Auramarine's expertise in biofuel systems. Choosing Auramarine for reliable and efficient biofuel solutions ensures a sustainable and compliant future for your energy needs.

Fuel changeover system

Controlled changeovers

Fuels with a wide range of properties can be used in diesel engines if these properties can be adequately controlled by the fuel handling system during the changeover process. These include, for example, high-viscosity heavy fuel oil (HFO) fuels, such as ISO 8217 standard residual fuels RMK700 or RMG380, or other high-viscosity residual fuels or blends. On the other hand, engines can use low-viscosity marine diesel fuel (MDF) fuels, such as ISO 8217 DMA, which is often referred to as MGO, or other low-viscosity fuels, such as ultra-low sulphur fuel oil (ULSFO), light fuel oil (LFO), and diesel fuel oil (DFO).

The challenge in instant fuel changeovers is that with a manually controlled fuel changeover system, it is almost impossible to simultaneously keep the fuel temperature change rate low enough (at a maximum rate of 2°C/min) and the viscosity high enough ($\geq 2\text{cSt}$) at the engine inlets.

Risks and solutions

- Injection pressure losses caused by too low a viscosity may result in difficulties during start-up and low-load operations
- Too low a viscosity reduces the fuel's effectiveness as a lubricant, which can result in fuel pumps sticking and working ineffectively

- In addition to the engine, other machinery with moving parts in the fuel-circulation system have minimum viscosity requirements. For these parts, a low viscosity can also cause malfunctions due to lubrication issues
- Interruptions in fuel supply during the changeover process can lead to reduced engine power or in the worst case scenario, total loss of propulsion, which could be hazardous for the vessel, its crew, passengers and cargo.

Auramarine's fuel changeover solution meets all these challenges.

Easy operation at sea

Changeover is initiated at the push of a button and all necessary steps are automatically controlled. It is suitable for various engine loads, fuel consumption rates and fuel system volumes; the minimum required engine load during changeover is 33%. There is no need for a vessel to reduce its speed during the fuel changeover process.

It is ideal for both newbuilds and retrofits.

A quick guide to relevant abbreviations

- MGO = marine gas oil
- HFO = heavy fuel oil
- MDO = marine diesel oil
- AMB = Auramarine feeder booster
- M, Mc, L, C, O = marine, marine compact, land, crude, offshore
- 02-07; 12-26; 36-60 = unit sizes for 2~60 MW engine(s)
- TT, SS, TE, SE, EE = heating: thermal oil, steam, thermal/electric, steam/electric, electric (if MGO is used as a fuel no heater is required)
- SSE, TTE = combination heating: 2 x steam/2 x thermal and electric heater
- LT, SW = low temperature, fresh water or sea water. Used with integrated coolers
- P, T = plate, tube cooler types
- EP = emergency pump
- MP = electrically-driven add-on pump for MGO and MDO
- F1, F2, F3 = number of additional flowmeters
- mA = milliampere/electrical current

Auramarine is your trusted fuel systems expert for the marine and power industries. Our proud heritage stems from the company's foundation in Finland in the early 1970s. Since then we have delivered over 16,000 robust and reliable auxiliary systems to our customers all over the world, continuously aiming for superior service and customer value.

WE ARE THE PIONEERS IN FUEL SYSTEMS.

AURAMARINE LTD

P.O. Box 849 FI-20101 Turku FINLAND

+358 20 486 5030

sales@auramarine.com

after.sales@auramarine.com

www.auramarine.com

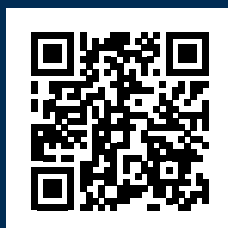

ID 603946



Information in this publication is subject to change without notice. In case of any difference between the reference documents and the technical specification, the technical specification shall overrule. All rights reserved. No part of this document may be reproduced, stored, photocopied, recorded or transmitted without permission of the copyright owner.