

# MGO units

Auramarine Marine Gas Oil supply solutions support operational and environmental efficiency by enabling flexible use of fuels. They comprise MGO Feeder units, or a range of combinations of MGO Feeder part, and MGO Booster part(s) designed to serve single or multiple engine configurations.

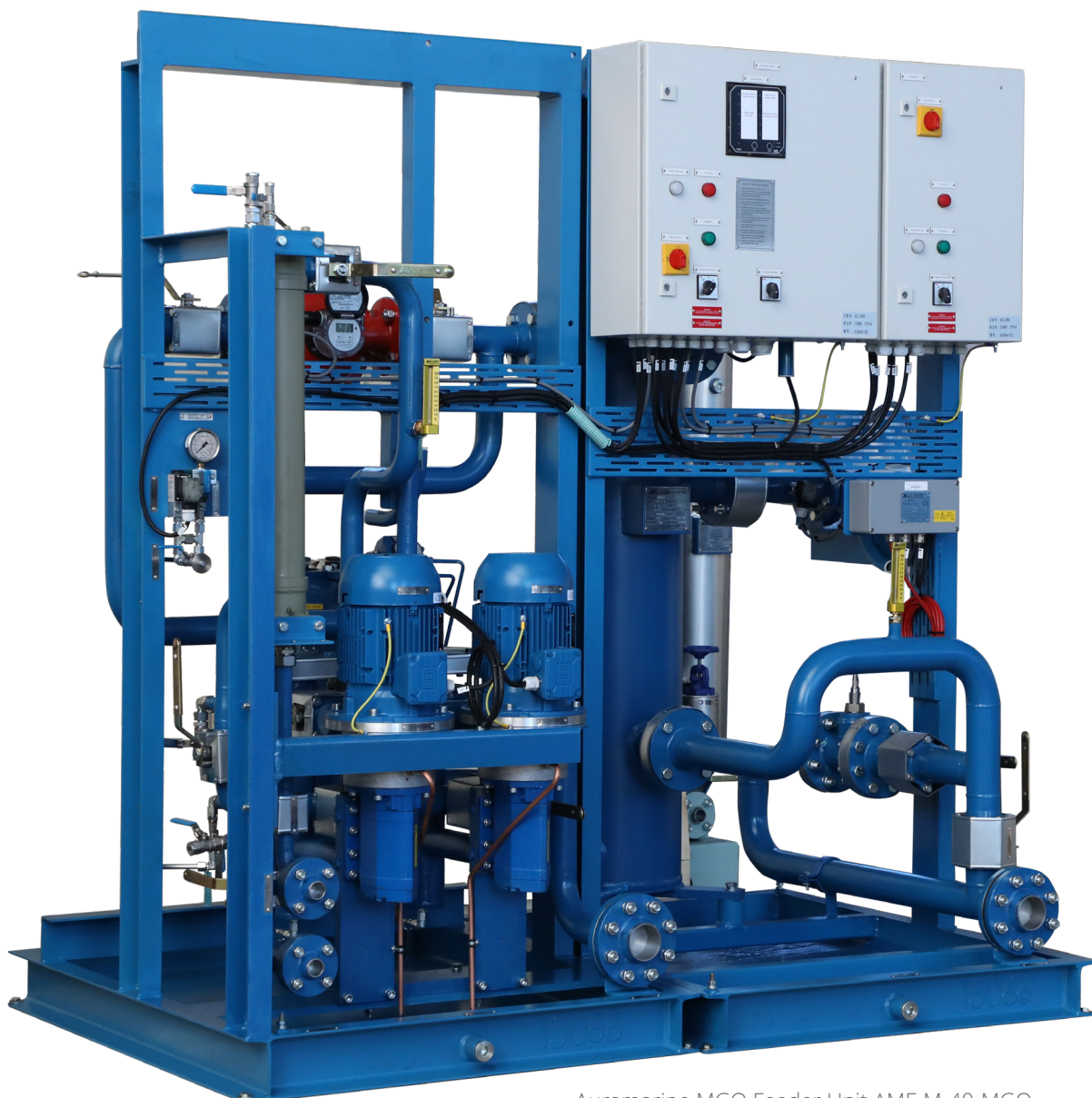

Auramarine MGO Feeder Unit AMF-M-40-MGO

## Added fuel flexibility through MGO supply unit retrofit

Auramarine MGO supply units control the fuel injection viscosities, flow rates and fuel pressure in turn ensuring that a fuel's condition continuously supports engine-specific requirements.

Low sulphur MGO has a low viscosity and usually fails to fill the minimum viscosity requirements of main engines. With our MGO units, the viscosity of MGO can be increased to meet these and lubrication requirements through cooling the oil.

Auramarine MGO supply units can be designed and installed on a retrofit basis, and are ideal for vessels with multi-engine configurations, where one conventional booster is feeding two or more engines.

With the installation of an additional MGO fuel supply unit, different engines can be operated on different liquid fuels (HFO-MGO). The ability to readily change fuels is especially advantageous in the case of ships with scrubber installations.

## Space-saving installation

All Auramarine fuel supply units are designed and manufactured to fit seamlessly into a ship's fuel system. Since space-consuming heaters, heavy automatic filters and thermal insulation are not normally required in MGO operation, the footprint of the MGO feeder-booster is remarkably smaller compared to a conventional HFO supply unit.

In addition, when such expensive components are not required, MGO fuel supply systems are also a cost-effective solution.

Auramarine MGO supply units can be tailored as a feeder part connected to existing booster(s) or a fully independent complete MGO supply unit depending on the engine configuration.

## Options

- For retrofit projects the space constraints on the way to the engine room and in the installation area can be challenging. With this in mind, we have designed an option which allows the unit to be split into two or three parts for smooth transport and installation.
- As a further option, Auramarine can support the update, and/or update the existing fuel oil system diagrams, and find the best solution to implement the new unit to the existing system.
- Available for both seawater and LT water configurations
- Emergency Pump unit for MGO (AEP) is also available as an option

## Capacities

Auramarine MGO units come in capacities equal to conventional Auramarine HFO boosters, power range 1-60 MW. Further capacities are available upon request.



Auramarine cooler Unit (ACU)

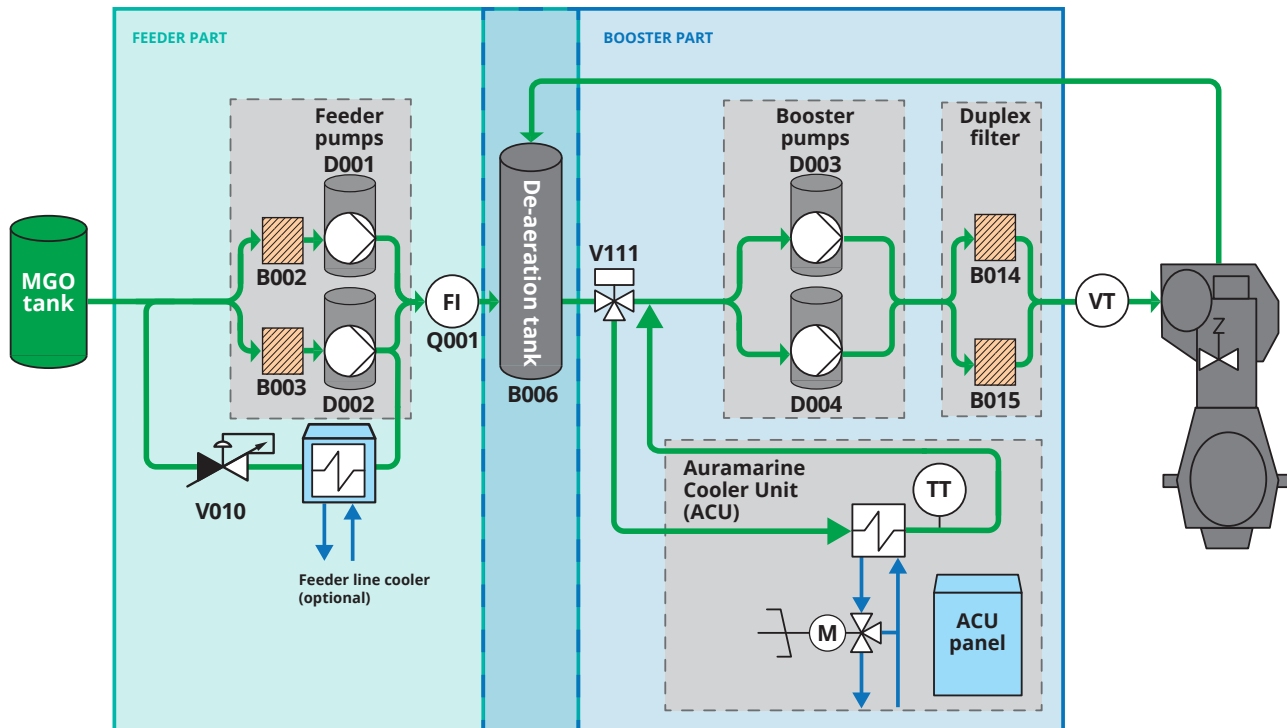

## Main components

**Suction strainers (B002, B003)** for protecting the pumps.

**Feeder pumps (D001, D002)** for pressurising the system with fresh fuel according to the consumption requirements of the engines. The feeder pumps are equipped with an automatic stand-by function and have magnetic or mechanical couplings. If a separate feeder unit is ordered, the booster unit does not include feeder pumps.

**Pressure control valve (V010)** for maintaining constant system pressure at different loads. This is supplied with or without a bypass system.

**Duplex filter with bypass filter (B014, B015)** for removing impurities from fuel oil. The degree of filtration is specified according to the engine manufacturer's recommendation or a customer's requirements.

**Flowmeter (Q001)** for indicating fuel consumption. Flowmeters have a local totalizer and output signal. They are available as mass or volumetric types.

**Mixing tank (B006)** for mixing the return fuel from the engines with fresh fuel and to help compensate for temperature and pressure changes. De-aeration is achieved manually or automatically.

**Booster pumps (D003, D004)** for further pressurising and circulating fuel to the engines. They are equipped with an automatic stand-by function and have magnetic or mechanical couplings. If needed, an individual circulating pump can be delivered for each engine.

**Viscosity measurement system (B016)** for measuring the fuel viscosity.

# Auramarine lifecycle services: from essential support to lifecycle optimisation

Auramarine's mission is to ensure the operational efficiency of your fuel supply system throughout its lifetime. From design and delivery to regular maintenance, we are by your side every step of the way and guarantee the latest retrofits and modernisation solutions once in service.

Every aspect of a ship's fuel supply system is crucial for maximising its operational efficiency and combustion system health.

The technical integrity of this system, achieved through diligent planning and preparation, helps keep your operational risks and costs at the lowest possible levels. It also ensures that your fuel system meets its intended requirements under pre-defined operating conditions.

## We offer:

- essential installation support for fuel supply unit
- commissioning fuel supply system
- inspections and preventative maintenance
- on demand maintenance and repairs
- rapid, worldwide delivery of high-quality spare parts
- spare parts kits for planned maintenance
- fuel supply performance optimisation
- upgrades, modernisations and retrofits
- training

ID664109

Information in this publication is subject to change without notice. In case of any difference between the reference documents and the technical specification, the technical specification shall overrule. All rights reserved. No part of this document may be reproduced, stored, photocopied, recorded or transmitted without permission of the copyright owner.



**Auramarine Ltd.**  
sales@auramarine.com  
after.sales@auramarine.com  
[www.auramarine.com](http://www.auramarine.com)

